

TPC-4600

INSTRUCTION MANUAL

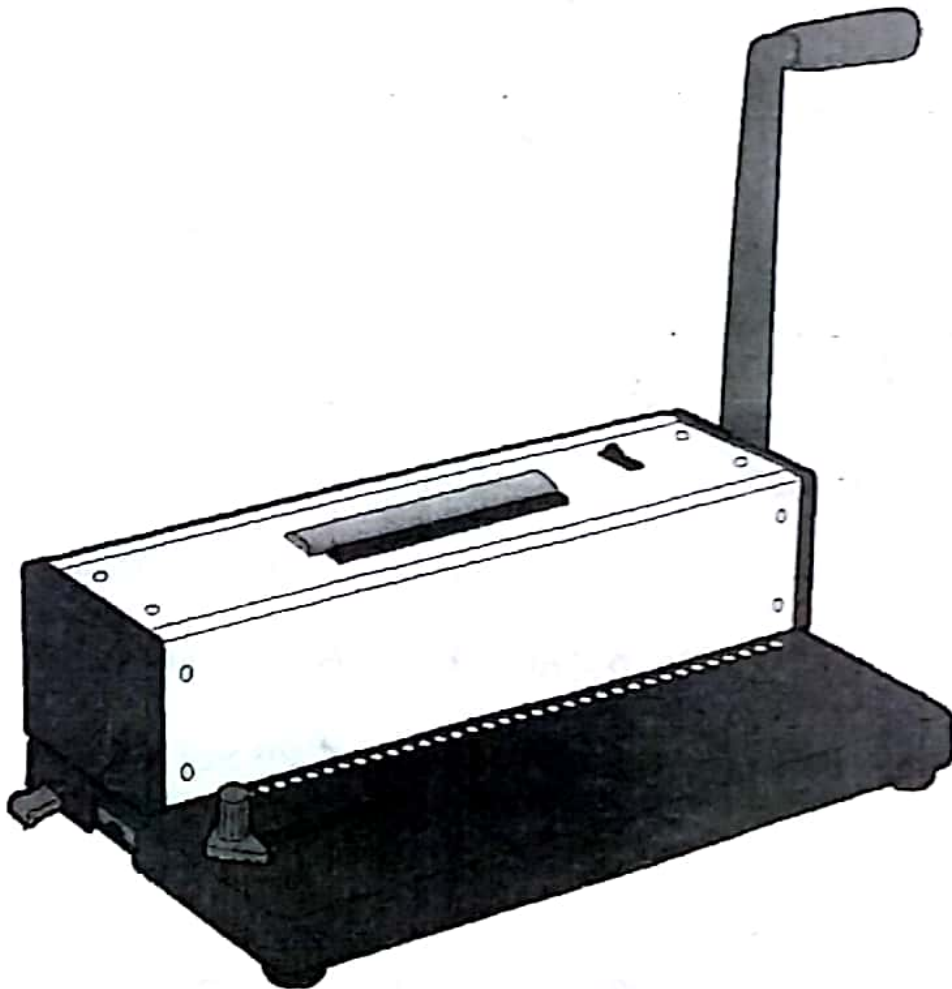

● STRUCTURE

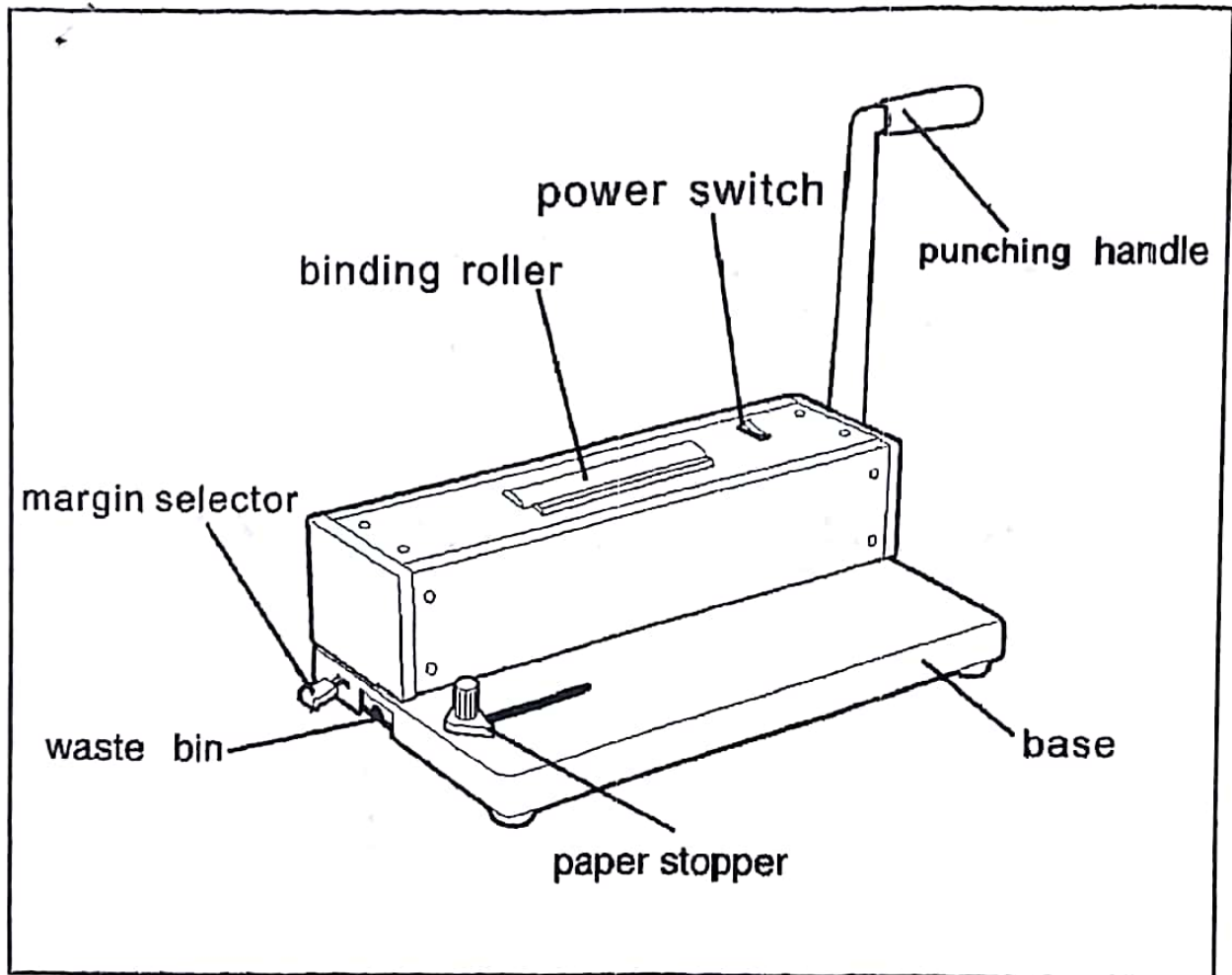

● FEATURES

Model : TPC-4600

Holes Qty : 46holes

Punching capacity : 15pages 75g A4 paper

Margins : 3, 5, 7mm

Binding capacity : 400pages 80g A4 paper

Net weight : 7.5KG

Machine dimension : 380x220x130mm

Holes size : Φ 3.5mm

⚠ CAUTION

▶ NEVER OVER LOAD PUNCHING

▶ CLEAN THE WASTE BIN AFTER EACH 100 TIMES PUNCHING

● OPERATION

① SET UP THE MACHINE

- ▶ The machine should be placed on a flat and stable working surface.
- ▶ Fix the handle to the shaft from right side, fasten the screw
- ▶ Pull and push the handle, it should be moved smoothly
- ▶ Insert the oil removing paper, punching several times. In order to remove the oil on the blades

○ MARGIN SETTING

- ▶ pull or push the margin selector to set the right margin

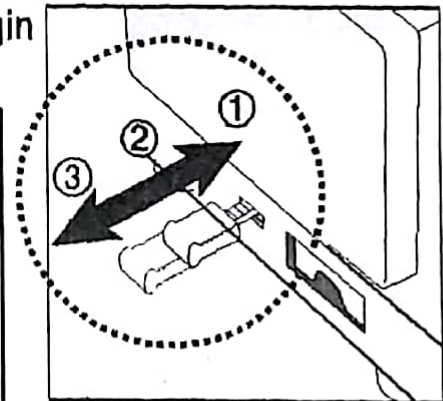
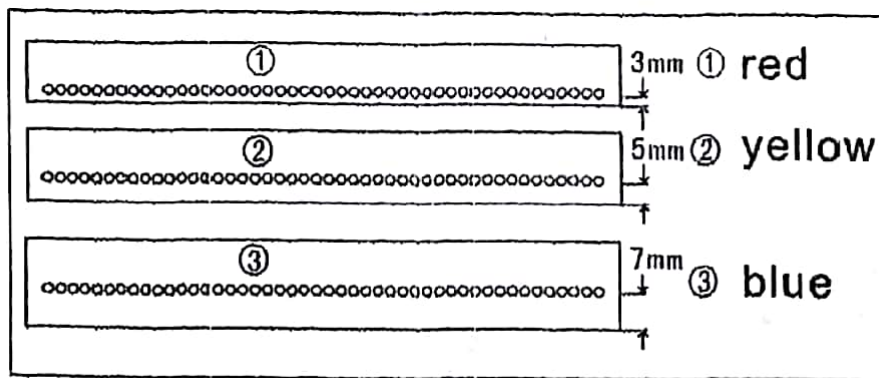

Tip

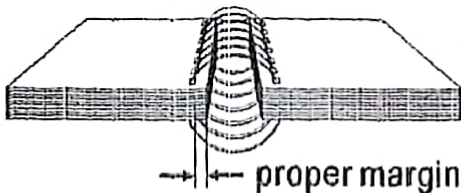

choice the proper binding ring and margin setting according to the sheets of file.

③ PUNCHING

- set margin and left side position
- insert file
- push down handle, punching

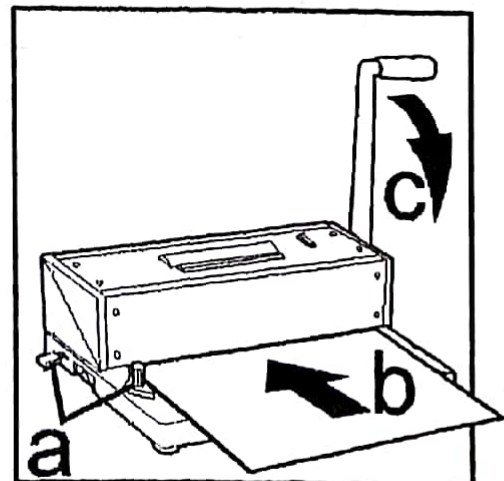

④ pre-treatment

Cut the front tip of binding ring as a acute angle. It will make it easier for inserting when binding. But this is not a necessary step. And it got to us a special pliers.

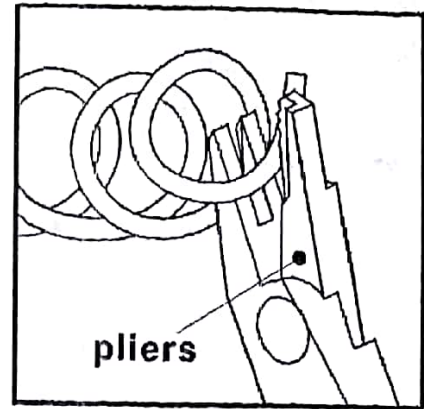

⑤ pre-inserting

roll to insert the first few rings in to the holes on the punched file.

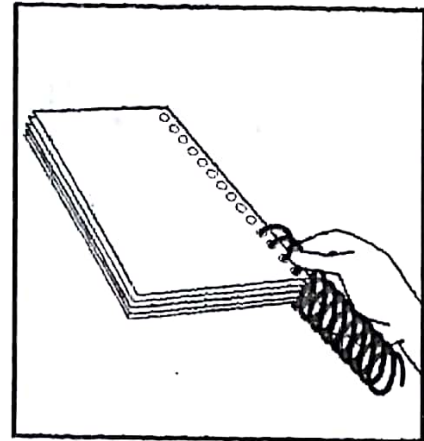

⑥ Binding

turn the switch on, the rubber binding roller begin rolling. Let the pre-inserted ring touch the roller and let the ring roll and bind.

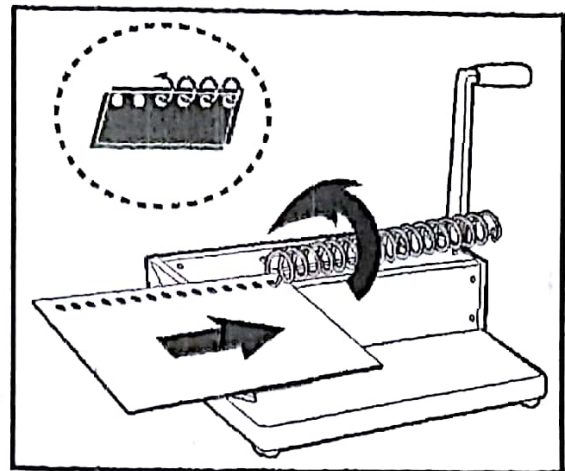

⑦ Post-treatment

Cut off the over long part of binding ring.

